

**E • Z CUT INC.**  
**OPERATOR'S MANUAL**  
**MODELS MK I AND MK II**

Dear Customer,

Congratulations on your purchase of this E-Z Cut cutting machine. The E-Z Cut machine has been carefully designed and constructed to provide you with many years of dependable service. This machine has been built to meet or exceed current CSA Standards. With proper care in operating and maintenance, this machine will ensure that all your cut lengths and orders are processed more efficiently.

To ensure yourself of the utmost value and performance from your purchase, read this manual carefully and ensure that your machine is operated correctly. Please be sure that you (and anyone who operates this machine) knows how to use the machine safely. Be thorough when going through instructions so that you are aware of the exact operation of all controls and of the correct procedures before the actual operation.

This manual provides you with step-by-step operation, normal care, troubleshooting, and adjustment procedures for your cutting machine. However, if help is needed with any of these procedures, E-Z Cut Inc. will be happy to assist you.

**E-Z CUT INC.**

## **SAFETY RULES**

### **General**

1. Read the operator's manual carefully.  
Please ensure that you are familiar with the controls and the proper use of the equipment.
2. Never allow children to operate the machine.  
Please ensure that only properly trained personnel operate the machine.
3. Keep the area of operation clear of all persons, particularly small children.

### **OPERATING PROCEDURES**

The following is the cutting machine's operating procedures. If the machine is in top working condition and no problems exist there should be no disruption in the procedures. If there are any problems refer immediately to the troubleshooting chart before proceeding any further in the steps to cutting your flooring material.

The procedures in this section are arranged in the normal sequence of operations. The arrangement is intended primarily to acquaint you as the operator with the fundamental operating procedures to ensure safe, efficient operation of your cutting machine.

**WARNING** When connecting the machine to the power source, electrical extension cord No. 14/2 GA Extension cord **MUST BE USED**. The motor could be damaged if proper extension cord is not used.

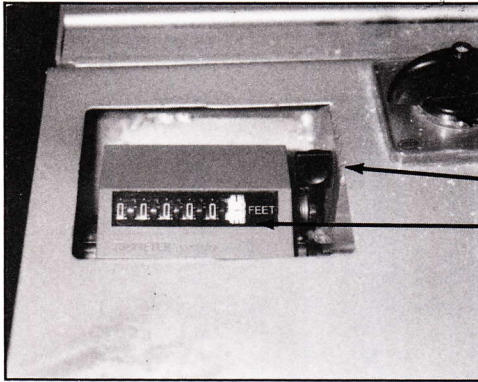

- SWITCH FORWARD & REVERSE
- COUNTER RE-SET LEVER
- COUNTER AVAIL. IN FEET & INCHES OR METRIC

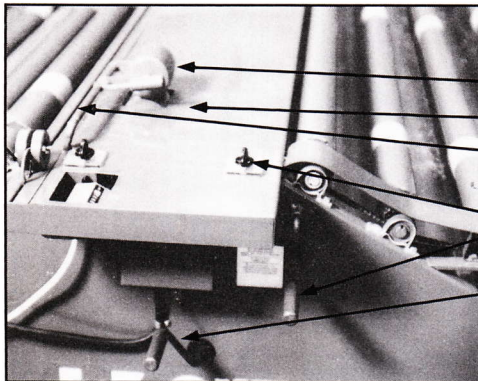

- COUNTER WEIGHT
- COUNTER ROLLER
- CUTTING BLADE
- CLUTCH TO DISENGAGE ROLLERS ON RIGHT SIDE
- SWITCH TO ACTIVATE CUTTING BAR
- (OPTIONAL) REVERSE ROLL EXCHANGE

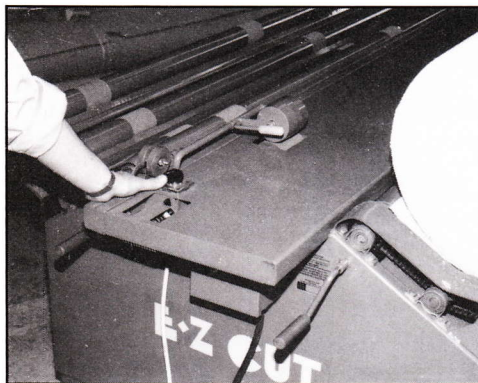

Place roll of carpet or vinyl flooring on the machine. Please ensure the feed is coming from the bottom towards the counter. Advance carpet forward or reverse by the hand control switch.  
**NOTE:** To tighten loose roll of carpet, roll carpet in reverse direction until it tightens up.

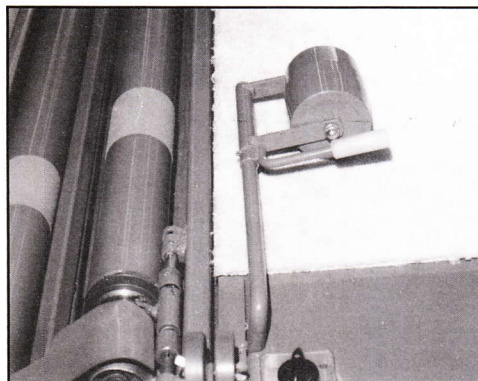

As carpet rolls towards the left hand rollers, guide carpet underneath the counter weight and stop at cutting bar edge. This will tell you if carpet edge is straight. If not adjust roll accordingly - manually.

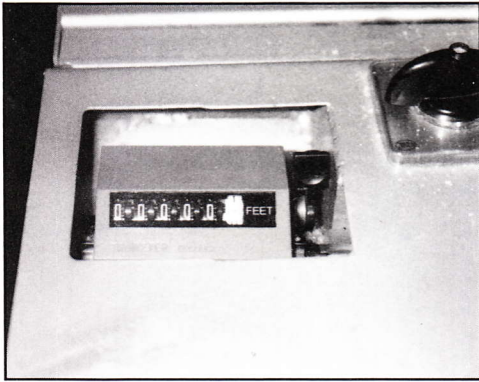

Re-set counter to 00000 by depressing the re-set button on the counter. At this point the counting process of the carpet begins.



As you start rolling the flooring, guide the floor covering by pulling gently on the edge of the carpet with your left hand, as shown on photo

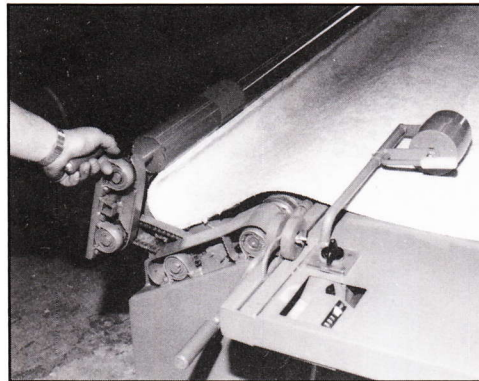

To start rolling the floor covering material pull up the roller to guide carpet. As on picture. (This can also be done with a flooring core inserted.)

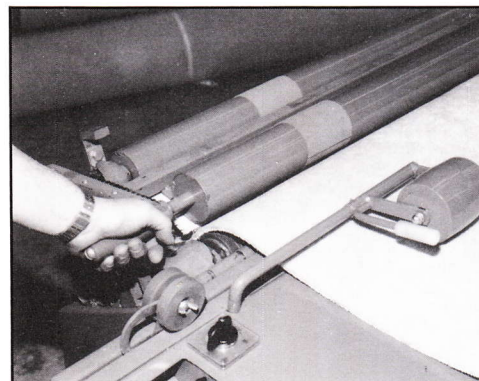

Close rollers as shown to ensure proper rolling start. (photo at left).

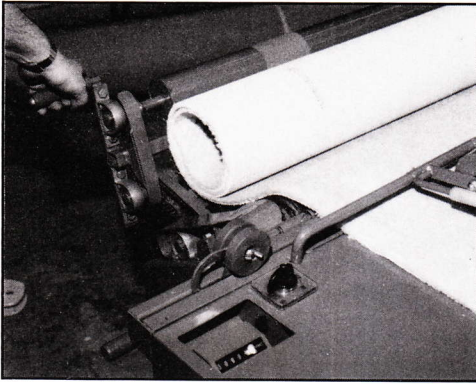

Open rollers as shown. Hold until there is approximately 4 to 5 feet of flooring material rolled up. Place roller(s) back to standard position.

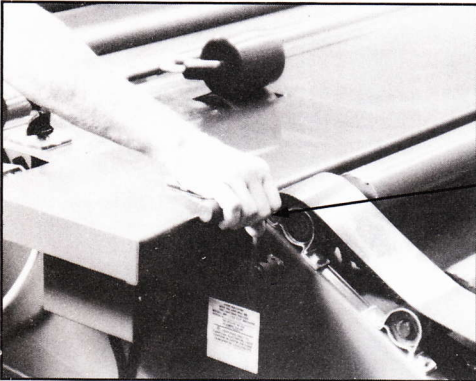

Once desired length is achieved stop roller(s), disengage right side rollers by pulling clutch upward to disengage position.

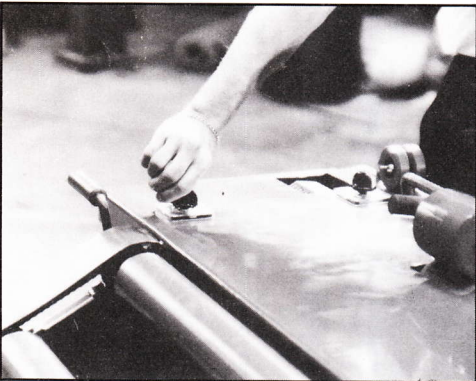

To cut the floor material engage cutting bar by turning control switch to forward position to engage cutting process. Once the flooring is cut return blade by turning switch to reverse.



To roll, wrap or tape floor covering, disengage cutting blade by pushing the right clutch bar down to disengage position. This will allow the roller on the left hand side to roll freely. This can be controlled by the hand control switch or by the foot pedal switch.

**NOTE:** To remeasure a full or partial roll of flooring add 4" to measurement shown on the counter.

# OPTIONAL EQUIPMENT - REVERSE ROLLER

## PROCEDURE TO REVERSE ROLL CARPET (PILE OUT)

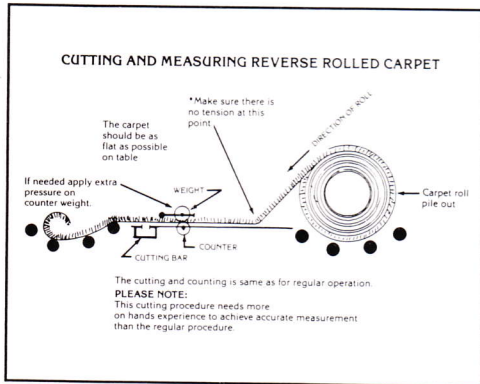

To reverse roll carpet push reverse clutch handle in the down position. Make sure that the rollers on the right side rolls reverse.

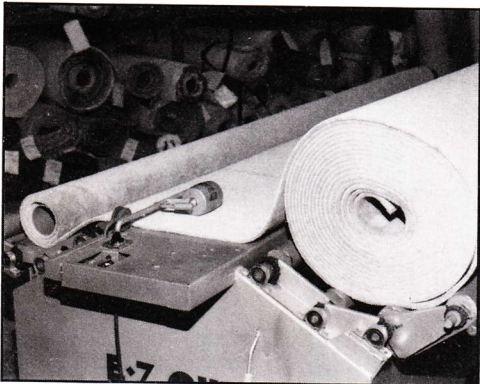

When loading carpet to be reverse rolled, carpet must be un-rolling from top as shown with backing facing up.

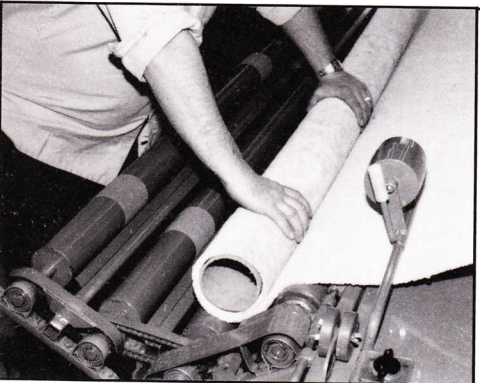

To begin the reverse roll procedure you must start it by hand as shown. The foot switch will activate the roll up procedure now.

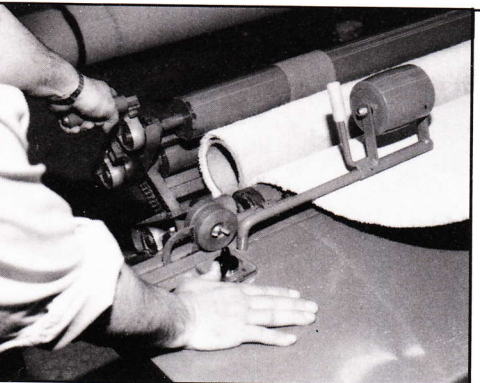

To insure that the roll stays tight lift up handle and roll up approx. 5 ft. to 6 ft. of carpet before returning rollers to regular position.

**NOTE:** Accurate measurement of carpeting with the above procedure is not possible.

## COMPONENTS

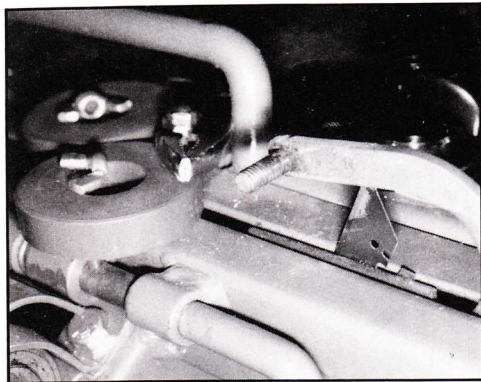

To change cutting blade remove plastic rollers as shown pull out standard utility blade and turn around or replace as required

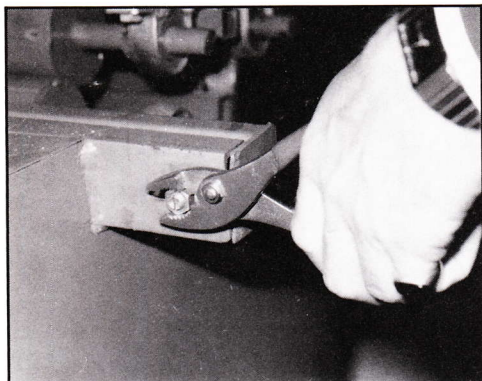

To loosen or tighten cutting chain turn nut as shown.

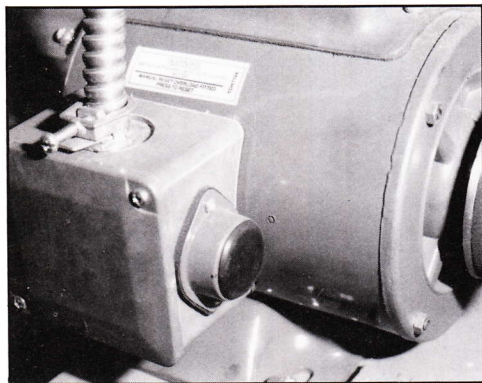

Re-set button on motors.

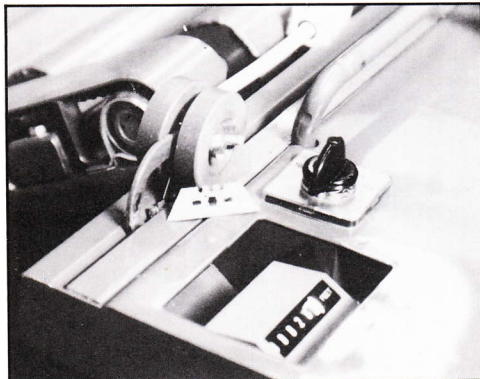

E-Z Cut Recommended Blades  
Dexter 73C  
Roberts #10-434  
(Available from E-Z Cut Inc.)  
For Blade Replacement Instructions  
please refer to page 10.



# WORM GEAR REDUCER

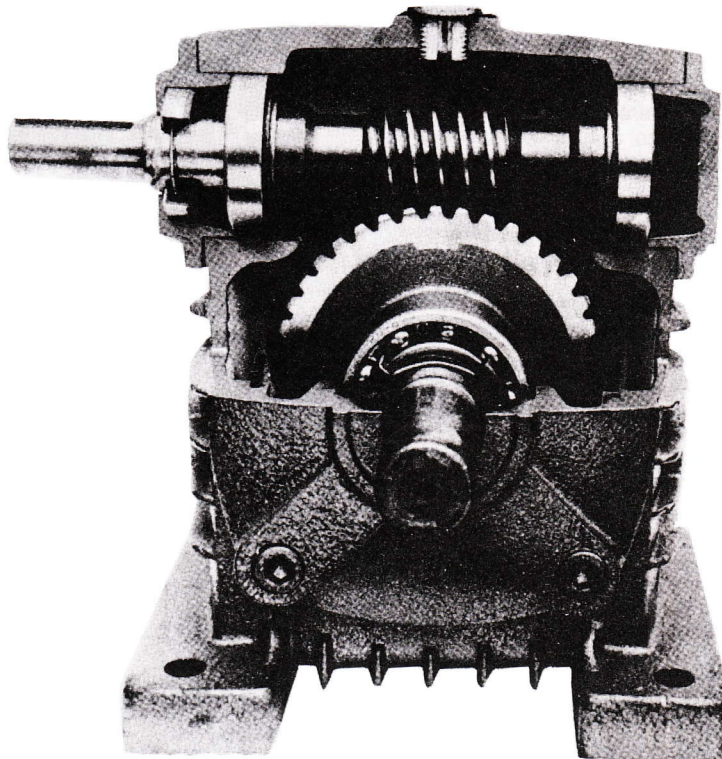

**After 85 hours of operation:** Drain unit and flush with light oil. Refill.

**Every 2500 hours of operation:** Drain, flush and refill.

**Regular inspection.**

Check your Reducer's mounting bolts and couplings for tightness regularly. Check the unit's oil level in the sight gauge. Remove the oil fill cap, check that the breather hole has not been plugged by dust or refuse, and visually check gears for signs of wear.

## Manufacturer's Recommended Lubricants for Worm Gear Speed Reducers

	Mineral Oil		Compounded Oil		Extreme Pressure	
	15 to 60F -9 to 60C	50 to 125F 10 to 52C	15 to 60F -9 to 16C	50 to 125F 10 to 52C	15 to 60F -9 to 16C	50 to 125F 10 to 52C
Ambient Temperature	15 to 60F -9 to 60C	50 to 125F 10 to 52C	15 to 60F -9 to 16C	50 to 125F 10 to 52C	15 to 60F -9 to 16C	50 to 125F 10 to 52C
AGMA	5	6	7	8	7EP	8EP
SSH @210F(99C)	80-105	105-125	125-150	150-190	125-150	150-190
Atlantic Richfield Co.	Duro S-1000		Modoc 175	Modoc 175	Pennant NL 2500	Pennant NL S-3150
Chevron Oil Company	Chevron OC Turbine Oil 220	Chevron Borate AP Lub Heavy Duty 320	Chevron Cylinder Oil 460X	Chevron Cylinder Oil 680X	Chevron Gear NL Compound 460	Chevron Gear NL Compound 680
Mobil Oil Corporation	DTE Oil BB	DTE Oil AA	Mobil 600 W Cylinder Oil	Mobil 600 W Super Cylinder Oil	Mobil Gears 634	Mobil Gears 636
Texaco Inc.	Regal Oil R&O 320	Regal Oil 320	631-Honor Cylinder Oil	624-650T Cylinder Oil	Meropa 460	Meropa 680
Union 76 Div. Union Oil Co. of CA	Union Turbine Oil 220	Union Turbine Oil 320	Union Steaval A	Union Worm Gear Lube 140	Union NL Lube 7EP	Union NL Lube 8EP

MK-1 MK-2

# E-Z CUT CARPET CUTTING MACHINE

WIRING DIAGRAM

MOTOR 1/2 or 3/4 HP 115/230V

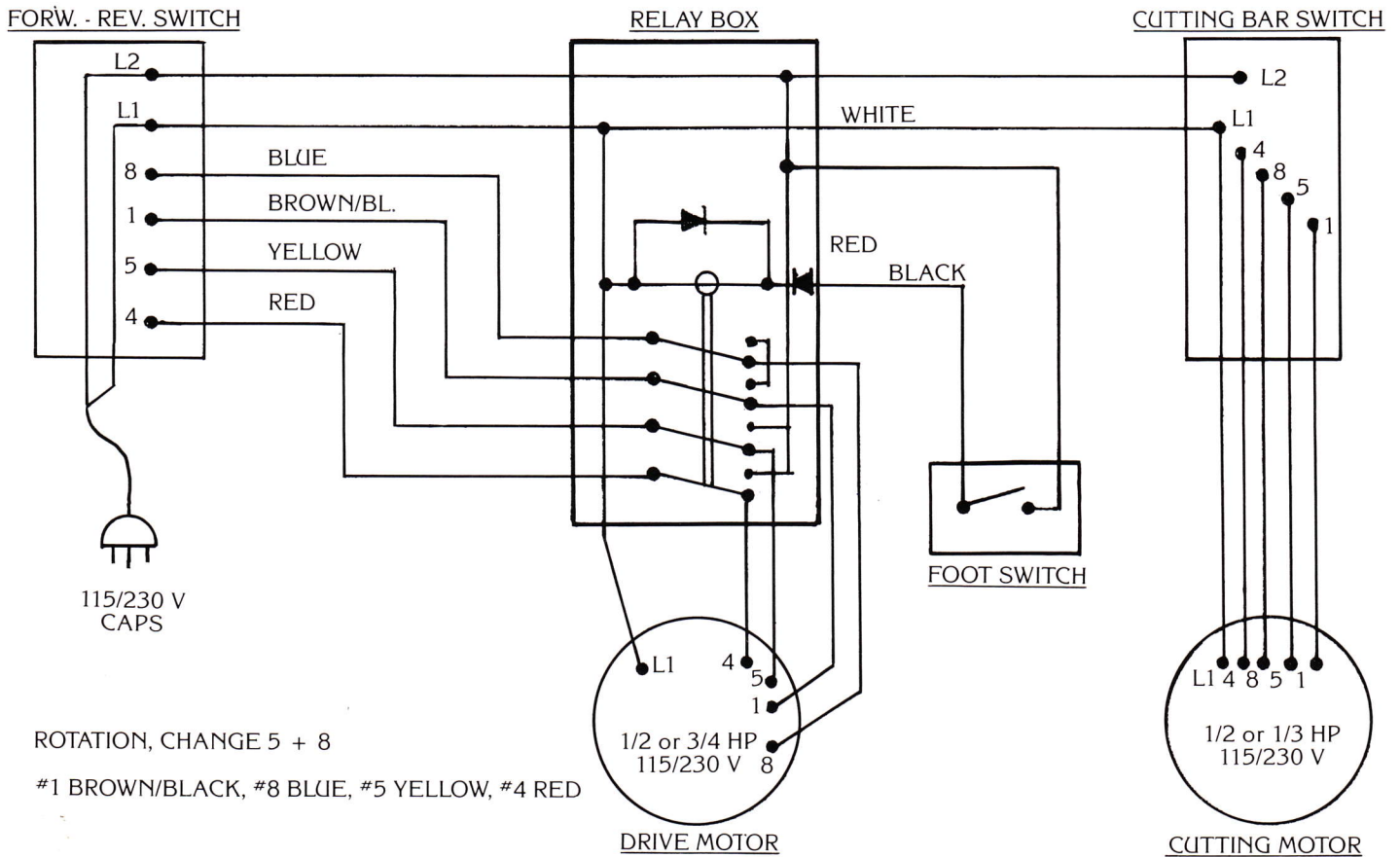

## BLADE REPLACEMENT INSTRUCTIONS

BLADE LOCK LEVER  
IN UPWARD POSITION

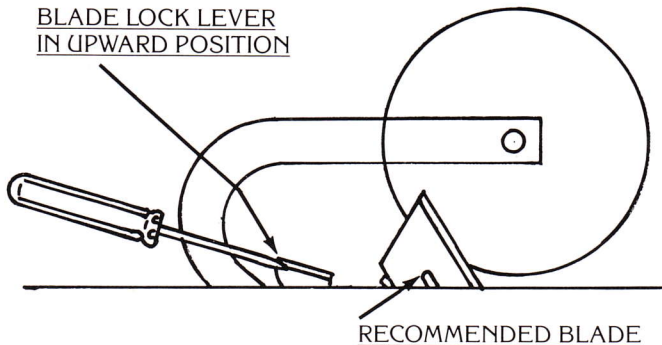

Removal: Pry blade lock lever to the upward position. Pull blade out of the holder.

Installation: Keeping the blade lock lever in the upward position, insert recommended blade into the holder.

Ensure that the blade is pushed all the way down and depress the blade lock lever to the downward position.

# TROUBLESHOOTING

This section of the manual provides troubleshooting and repair instructions for the more common and easily corrected problems. For other problems, it is recommended that you contact our offices.

PROBLEM	CAUSE/REMEDY
CUTTING BAR AND OR MACHINE WILL NOT TURN FORWARD OR REVERSE	<ul style="list-style-type: none"> <li>A. Make sure electrical power is supplied to plug.</li> <li>B. Push motor re-set button on side of motor(s).</li> </ul>
CUTTING BLADE WILL NOT MOVE OR STICKING	<ul style="list-style-type: none"> <li>A. Tighten cutting chain by turning bolt at end of cutting bar.</li> <li>B. If carpet fibres fill up cutting bar, loosen chain and clean out cutting bar and tighten chain.</li> <li>C. Visually check cutting bar for obstructions and remove fallen blades, etc.</li> </ul>
RIGHT CLUTCH ARM NOT ENGAGING	<ul style="list-style-type: none"> <li>A. Replace missing or broken roll pin (1/4" x 5/8") Avail. at any hardware store or machine shop.</li> </ul>
MACHINE IS MAKING A GRINDING SOUND WHEN FOOT PEDAL SWITCH IS ENGAGED.	<ul style="list-style-type: none"> <li>A. Use a heavier extension cord as recommended in operating manual.</li> <li>B. Test amperage from direct electrical source.</li> <li>C. Check relay switch for proper contacts.</li> </ul>
COUNTER METER NOT REGISTERING	<ul style="list-style-type: none"> <li>A. Tighten Hex nut (Allen Key) on counter roller.</li> <li>B. Ensure counter shaft is securely connected to counter roller shaft.</li> </ul>
METER NOT COUNTING ACCURATELY	<ul style="list-style-type: none"> <li>A. Apply weight on counter roller handle. This problem may occur with a very thin product lightweight level loop or if carpet being registered is rolled pile out.</li> <li>B. When the carpet is rolling up uneven (coned) adjust rolls accordingly in roller cradles.</li> </ul>
BROKEN ROLLER CHAIN LINK	<ul style="list-style-type: none"> <li>A. Replace with #35 standard link available at any hardware store or machine shop.</li> </ul>

## MAINTENANCE TIPS

- \*\*\* Ensure roller and cutting bar chains are well lubricated. (Use WD40 or light weight machine oil.)
- \*\*\* Ensure clutch assembly on right side roller is packed with grease (very important).
- \*\*\* Ensure cutting bar is clean and free from obstructions.
- \*\*\* Use only E-Z Cut recommended blades.

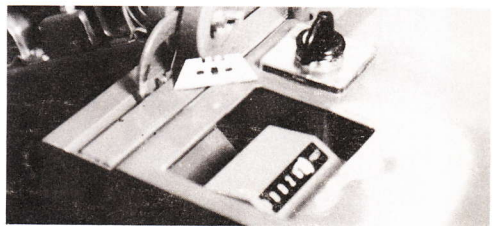
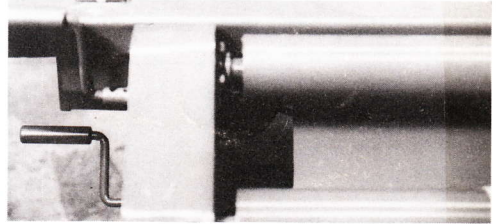

## E-Z Cut Warranty

E-Z Cut Inc. warrants our products to be free from defects in materials and workmanship for the period of one year. E-Z Cut was designed and manufactured with serviceability and ease of maintenance in mind. In the event that you should require any service work, we recommend that you contact a qualified electrician or machinist in your area. Also contact our office accordingly.

*For further information pertaining  
to this manual please contact*

### **E-Z CUT INC.**

433 St. Mary's Rd.  
Wpg. Man. R2M 3H7  
Ph. (204)235-1122, Fax (204)237-9339